**Geotextiles and geotextile-related
products — Determination of water
permeability characteristics normal to the
plane, without load**

*Géotextiles et produits apparentés — Détermination des
caractéristiques de perméabilité à l'eau normalement au plan, sans
contrainte mécanique*



PDF disclaimer

This PDF file may contain embedded typefaces. In accordance with Adobe's licensing policy, this file may be printed or viewed but shall not be edited unless the typefaces which are embedded are licensed to and installed on the computer performing the editing. In downloading this file, parties accept therein the responsibility of not infringing Adobe's licensing policy. The ISO Central Secretariat accepts no liability in this area.

Adobe is a trademark of Adobe Systems Incorporated.

Details of the software products used to create this PDF file can be found in the General Info relative to the file; the PDF-creation parameters were optimized for printing. Every care has been taken to ensure that the file is suitable for use by ISO member bodies. In the unlikely event that a problem relating to it is found, please inform the Central Secretariat at the address given below.



COPYRIGHT PROTECTED DOCUMENT

© ISO 2010

All rights reserved. Unless otherwise specified, no part of this publication may be reproduced or utilized in any form or by any means, electronic or mechanical, including photocopying and microfilm, without permission in writing from either ISO at the address below or ISO's member body in the country of the requester.

ISO copyright office
Case postale 56 • CH-1211 Geneva 20
Tel. + 41 22 749 01 11
Fax + 41 22 749 09 47
E-mail copyright@iso.org
Web www.iso.org

Published in Switzerland

Contents

Page

Foreword	iv
1 Scope	1
2 Normative references	1
3 Terms and definitions	1
4 Test specimens	2
4.1 Handling	2
4.2 Selection	2
4.3 Number and dimensions	2
4.4 Condition of specimens	2
5 Constant head method	2
5.1 Principle	2
5.2 Apparatus	2
5.3 Procedure	3
5.4 Calculation and expression of results	4
6 Falling head method	4
6.1 Principle	4
6.2 Apparatus	5
6.3 Procedure	6
6.4 Calculation and expression of results	6
7 Test report	7
Annex A (informative) Determination of the correction factor, R_T, to a water temperature of 20 °C	12
Annex B (informative) Relationship between head loss and flow velocity	14
Annex C (informative) Velocity index	16
Annex D (informative) Experimental data and calculations	17

Foreword

ISO (the International Organization for Standardization) is a worldwide federation of national standards bodies (ISO member bodies). The work of preparing International Standards is normally carried out through ISO technical committees. Each member body interested in a subject for which a technical committee has been established has the right to be represented on that committee. International organizations, governmental and non-governmental, in liaison with ISO, also take part in the work. ISO collaborates closely with the International Electrotechnical Commission (IEC) on all matters of electrotechnical standardization.

International Standards are drafted in accordance with the rules given in the ISO/IEC Directives, Part 2.

The main task of technical committees is to prepare International Standards. Draft International Standards adopted by the technical committees are circulated to the member bodies for voting. Publication as an International Standard requires approval by at least 75 % of the member bodies casting a vote.

Attention is drawn to the possibility that some of the elements of this document may be the subject of patent rights. ISO shall not be held responsible for identifying any or all such patent rights.

ISO 11058 was prepared by Technical Committee ISO/TC 221, *Geosynthetics*.

This second edition cancels and replaces the first edition (ISO 11058:1999), which has been technically revised.

Geotextiles and geotextile-related products — Determination of water permeability characteristics normal to the plane, without load

1 Scope

This International Standard specifies two test methods for determining the water permeability characteristics of a single layer of geotextile or geotextile-related product normal to the plane:

- a) the constant head method;
- b) the falling head method.

NOTE If the full permeability characteristics of the geotextile or geotextile-related product have previously been established, then for control purposes it can be sufficient to determine the velocity index at a head loss of 50 mm only.

2 Normative references

The following referenced documents are indispensable for the application of this document. For dated references, only the edition cited applies. For undated references, the latest edition of the referenced document (including any amendments) applies.

ISO 2854, *Statistical interpretation of data — Techniques of estimation and tests relating to means and variances*

ISO 5813, *Water quality — Determination of dissolved oxygen — Iodometric method*

ISO 9862, *Geosynthetics — Sampling and preparation of test specimens*

ISO 10320, *Geotextiles and geotextile-related products — Identification on site*

3 Terms and definitions

For the purposes of this document the following terms and definitions apply.

3.1

velocity index

V_{H50}

velocity corresponding to a head loss of 50 mm across a specimen, expressed to the nearest ± 1 mm/s

4 Test specimens

4.1 Handling

The sample shall not be folded and shall be handled as infrequently as possible to avoid disturbance to its structure. The sample shall be kept in a flat position without any load.

4.2 Selection

Take specimens from the sample according to ISO 9862.

4.3 Number and dimensions

Cut five test specimens from the sample, each of suitable dimensions for the water permeability apparatus to be used.

If it is necessary to determine the results to within a given confidence interval of the mean, the number of test specimens shall be determined in accordance with ISO 2854.

4.4 Condition of specimens

The specimens shall be clean, free from surface deposits and without visible damage or folding marks.

5 Constant head method

5.1 Principle

A single, unloaded layer of geotextile or geotextile-related product is subjected to a unidirectional flow of water normal to the plane under a range of constant heads.

5.2 Apparatus

5.2.1 Apparatus in which it is possible to observe the presence of air bubbles on the surface of the specimen, with an internal diameter of minimum 50 mm, complying with the following requirements.

- a) The apparatus shall be capable of installing a maximum head loss of at least 70 mm and maintaining a constant head for the duration of each test with water on both sides of the specimen. It shall be capable of achieving a constant water head of up to 250 mm.

NOTE Some examples of apparatus are shown in Figure 1.

- b) The mean internal diameter of the apparatus shall be known to an accuracy of at least 0,1 mm. The exposed diameter of the specimen shall be the same as the internal diameter of the apparatus. The diameter of the apparatus shall remain identical on both sides of the specimen over a length of at least twice its internal diameter [see Figures 1 a) and 1 b)]. Abrupt changes in diameter shall be avoided.

Alternatively [see Figure 1 c)], the outflow may discharge into a reservoir with a diameter of at least four times the exposed diameter of the specimen. In this case, the distance from the geotextile to the base of the reservoir shall be at least 1,5 times the exposed diameter of the specimen.

If the product shows an obvious pattern, this pattern shall be included at least three times along any diameter of the specimen.

- c) Where necessary, to avoid any visible deformation, a grid of 1 mm diameter wire and a mesh size of (10 ± 1) mm shall be placed downstream of the specimen to support it during the test.
- d) The head loss measured at any velocity when a test is performed without the test specimen, but including any specimen-supporting grid, shall be less than 1 mm.

5.2.2 Water supply, of the following quality and condition.

- a) The water shall be at a temperature of between 18 °C and 22 °C.

NOTE As the temperature correction (see Annex A) relates only to laminar flow, it is advisable to work at temperatures as close as possible to 20 °C to minimize inaccuracies associated with inappropriate correction factors, should the flow be non-laminar.

- b) Water may not be fed into the apparatus directly from a mains supply due to problems caused by the release of air bubbles, which can be entrapped in the structure of the specimen. The water should preferably be de-aired or fed from a stilling tank. The water should not be continuously recycled.
- c) The oxygen content shall not exceed 10 mg/kg. The oxygen content shall be measured at the point at which the water enters the apparatus.
- d) The water shall be filtered if suspended solids are visible to the naked eye or if solids accumulate on or in the specimen, thus reducing the flow with time.

5.2.3 Dissolved-oxygen meter, or apparatus complying with ISO 5813.**5.2.4 Stopwatch**, with an accuracy of 0,2 s.**5.2.5 Thermometer**, with an accuracy of 0,5 °C.**5.2.6 Measuring vessel**, of appropriate size for determining the volume of water to an accuracy of 1 % of the capacity of the vessel.

When the water flow is determined by volume, use a measuring vessel for determining volume to an accuracy of 1 %. When direct measurement of water flow velocity is made by gauge, the flow velocity shall be measured to an accuracy of 5 %. When determining the water volume by mass, it shall be determined to an accuracy of 1 %.

5.2.7 Measurement device for determining the applied head, to an accuracy of 3 %.**5.3 Procedure**

5.3.1 Place the specimens under water containing a wetting agent at laboratory temperature, gently stir to remove air bubbles and leave to saturate for at least 12 h. The wetting agent is aryl alkyl sodium sulfonate at 0,1 % volume.

5.3.2 Place a specimen in the apparatus and ensure that all joints are watertight.

5.3.3 Fill the apparatus with water until there is a 50 mm water head difference across the specimen. Shut off the water supply and if the water heads do not equalize on each side of the specimen within 5 min, investigate the likelihood of any trapped air within the apparatus and repeat the procedure. If the water heads cannot be equalized within 5 min, this shall be noted in the test report.

5.3.4 Adjust the flow to attain a head loss of (70 ± 5) mm and record this value to the nearest 1 mm. When the head has been steady for a minimum of 30 s, collect the water passing through the system in the measuring vessel over a fixed period of time and record the volume of water collected to the nearest 10 cm³ and the time to the nearest 1 s. The volume of water collected should be a minimum of 1 000 cm³ and the collection time should be a minimum of 30 s.

When the water flow is determined by volume, the volume of the measuring vessel shall not exceed twice the volume of the collected water.

If a flow velocity gauge is used, then a maximum velocity giving a head loss of about 70 mm should be set. The real velocity shall be taken as the average of three consecutive readings with a minimum time interval between readings of 15 s.

5.3.5 Repeat 5.3.4 for four lower head losses of approximately 0,8; 0,6; 0,4 and 0,2 times the maximum head loss, starting with the highest velocity and ending with the lowest.

NOTE If the full permeability characteristics of the geotextile or geotextile-related product have previously been established, then for control purposes it can be sufficient to determine the velocity index at a head loss of 50 mm only.

The same principle applies to the velocity when using a flow velocity gauge.

5.3.6 Record the water temperature to the nearest 0,5 °C.

5.3.7 Repeat 5.3.2 to 5.3.6 with each of the remaining specimens.

5.4 Calculation and expression of results

5.4.1 Calculate the flow velocity, v_{20} , in metres per second, at 20 °C using Equation (1):

$$v_{20} = \frac{V R_T}{A t} \quad (1)$$

where

V is the water volume measured, in cubic metres;

R_T is the correction factor to a water temperature of 20 °C (see Annex A);

T is the water temperature, in degrees Celsius;

A is the exposed specimen area, in square metres;

t is the time measured to achieve the volume, V , in seconds.

Where the flow velocity, v_T , has been measured directly, a temperature correction is necessary according to:

$$v_{20} = v_T R_T \quad (2)$$

NOTE The flow velocity, v_{20} , expressed in millimetres per second, equals the discharge, q , expressed in litres per square metre second.

5.4.2 For each of the five specimens, calculate the flow velocity, v_{20} , for each head loss, H .

Plot the head loss, H , against velocity, v_{20} , and select the best-fit curve through the origin for each specimen (see Figure 2) in accordance with Annex B, either by mathematical or graphical means. Present the five specimen curves on one graph.

As indicated in the Note in Clause 1, it can be sufficient, for control purposes, to determine the flow velocity value at a head loss of 50 mm only.

5.4.3 Produce a flow velocity value at the head loss of 50 mm, either by calculation or by graphical interpretation.

6 Falling head method

6.1 Principle

A single unloaded layer of geotextile or geotextile-related product is subjected to a unidirectional flow of water normal to the plane under a falling head.

6.2 Apparatus

6.2.1 Transparent water-permeability apparatus, consisting of two interconnected vertical cylinders of the same diameter of minimum 50 mm, complying with the following requirements.

- a) The apparatus shall be capable of achieving water heads of at least 250 mm for appropriate calculations.

To achieve a water head of at least 250 mm, it is recommended to start with a higher water level because the water head values recorded during the opening time of the valve cannot be used for calculation.

- b) The mean internal diameter of the apparatus shall be known to an accuracy of at least 0,1 mm. The exposed diameter of the specimen shall be the same as the internal diameter of the apparatus. The diameter of the apparatus on both sides of the specimen shall remain identical over a length of at least twice its internal diameter. Within the range of changing water levels, the diameter shall be constant. Abrupt changes in diameter should be avoided.

If the product shows an obvious pattern, this pattern shall be included at least three times, along any diameter of the specimen.

- c) Where necessary, to avoid any visible deformation, a grid of 1 mm diameter wire and a mesh size of (10 ± 1) mm shall be placed downstream of the specimen to support it during the test.
- d) The head loss measured at any velocity when a test is performed without the test specimen but including any specimen-supporting grid shall be less than 1 mm.

NOTE Some examples of apparatus are shown in Figure 3.

- e) The connecting tube between the two cylinders shall have a minimum diameter of 40 % of the diameter of the cylinders. It shall be flexible if the weighing cell method is used.

6.2.2 Water supply, of the following quality and condition.

- a) The water shall be at a temperature between 18 °C and 22 °C.

As the temperature correction (see Annex A) relates only to laminar flow, it is advisable to work at temperatures as close as possible to 20 °C to minimize inaccuracies associated with inappropriate correction factors, should the flow be non-laminar.

- b) Water may not be fed into the apparatus directly from a main supply due to problems caused by the release of air bubbles which can lodge in the test specimen. The water should preferably be de-aired or fed from a stilling tank. The water in the apparatus should be replaced daily.
- c) The oxygen content shall not exceed 10 mg/kg. The oxygen content shall be measured at the point at which the water enters the apparatus.
- d) The water shall be filtered if suspended solids are visible to the naked eye or if solids accumulate on or in the specimen thus reducing the flow with time.

6.2.3 Dissolved-oxygen meter, or apparatus complying with ISO 5813.

6.2.4 Measuring device for determining the changing water head, with an accuracy of 3 %.

NOTE Possible means are:

- a) measuring the change in column mass (to ± 1 g);
- b) measuring the change in water pressure (to ± 1 Pa);
- c) measuring the change in water level by an optical method (reading of water level using digitalized video equipment) or by an ultrasonic method.

Continuous recording of the data by an analogue writer or computer, from the beginning to the end of the test, is recommended (see Figure 4).

6.2.5 Thermometer, with an accuracy of 0,5 °C.

6.3 Procedure

6.3.1 Place the specimens under water at laboratory temperature, gently stir to remove air bubbles and leave to saturate for at least 12 h. Aryl alkyl sodium sulfonate at 0,1 % volume is added as a wetting agent.

6.3.2 Place a specimen in the apparatus and ensure that all joints are watertight.

6.3.3 Fill the apparatus with water until there is a 50 mm water head difference across the specimen. Shut off the water supply and if the water heads do not equalize on each side of the specimen within 5 min, investigate the likelihood of any trapped air within the apparatus and repeat the procedure. If the water heads cannot be equalized within 5 min, this shall be noted in the test report.

6.3.4 Close the valve. Fill the specimen cylinder of the apparatus to a height such that a useful head difference of at least 250 mm after complete opening of the valve is achieved [see the second paragraph of 6.2.1 a)].

6.3.5 Record the water temperature to the nearest 0,5 °C.

6.3.6 Switch on all instruments required for the method used (see 6.2.4) and open the valve.

6.3.7 The test ends when head loss and flow velocity reach zero.

NOTE For highly permeable specimens, it is possible for the water levels at $v = 0$ m/s to not equalize due to inertia effects (see Figure 4). In these cases, the water level corresponding to $v = 0$ m/s for the first time is taken as the reference level for calculating head losses.

6.3.8 Repeat 6.3.2 to 6.3.7 with each of the remaining specimens.

6.4 Calculation and expression of results

6.4.1 From a chosen water-level interval on the graph of the analogue writer (see Figure 4) or the computerized data, calculate the flow velocity, v_{20} , in metres per second, at 20 °C, using Equation (3):

$$v_{20} = \frac{\Delta h}{t} R_T \quad (3)$$

where

Δh is the difference, in metres, between the upper water level, h_u , and the lower water level, h_l , at the time interval, t ;

t is the time interval between h_u and h_l , in seconds;

R_T is the correction factor to a water temperature of 20 °C (see Annex A);

and the head loss, H , in metres, which is given by:

$$H = h_u + h_l - 2h_0 \quad (4)$$

where

h_0 is the height of the water level at $v = 0$ m/s (see note in 6.3.7);

h_u and h_l are the upper and lower level of the head range on which the calculation is based.

NOTE The flow velocity, v , expressed in millimetres per second, equals the discharge, q , expressed in litres per square metre second.

6.4.2 For each of the five specimens, calculate the flow velocity, v , for each water head loss, H , at a minimum of five points along each curve.

In calculating the falling head curve, it is recommended that time intervals be 1/5 to 1/10 of the total time to carry out the experiment.

Plot the head loss, H , against velocity, v , and select the best-fit curve through the origin for each specimen, in accordance with Annex B, by either mathematical or graphical means. Present the five specimen curves on one graph (see Figure 2).

6.4.3 The test shall be used to produce a flow velocity value at the head loss of 50 mm either by calculation or by graphical interpretation.

7 Test report

The test report shall include the following information:

- a) the number and year of publication of this International Standard, i.e. ISO 11058:—;
- b) the test laboratory and, if required, the test operator;
- c) a description of the product tested in accordance with ISO 10320;
- d) the exposed specimen area;
- e) only where the full permeability characteristics are being measured, a collective plot of the velocity, v , and head loss, H , for each specimen;
- f) the velocity index for a head loss of 50 mm (V_{H50}) and, if required, specimen values, sample mean, specimen maximum and minimum (see Annex C);
- g) the water temperature range;
- h) the water type (stilled, de-aerated, de-ionized, filtered) and dissolved oxygen values;
- i) the type of flow gauge, if used;
- j) any deviation from this International Standard;
- k) any anomaly in the hydraulic behaviour of the product;

In addition, if required:

- l) details of apparatus used, including a diagram;
- m) the experimental data and calculations for each specimen can be tabulated. An example of such a table is given in Table D.1 (constant head method) or Table D.2 (falling head method).

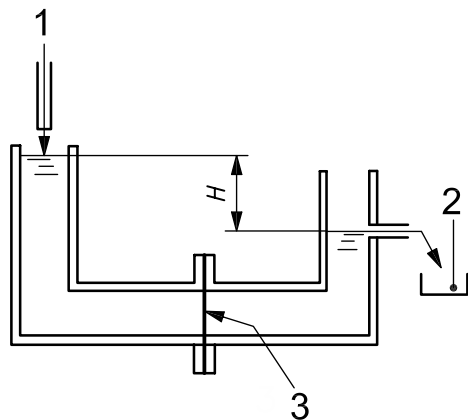

a) Horizontal

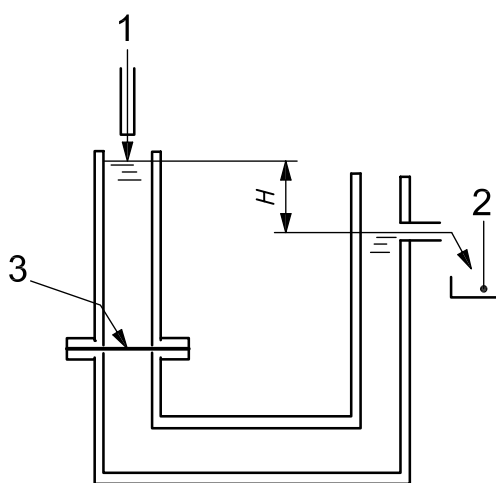

b) Vertical

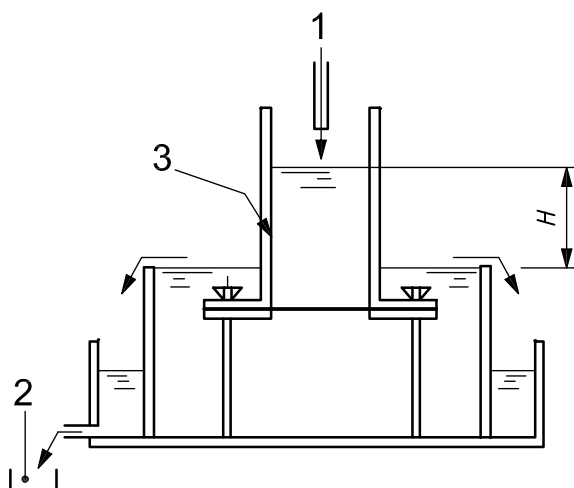

c) Open

Key

- | | |
|---------------------|---------------|
| 1 inflow | 3 specimen |
| 2 collected outflow | H head loss |

Figure 1 — Examples of apparatus for the constant head method

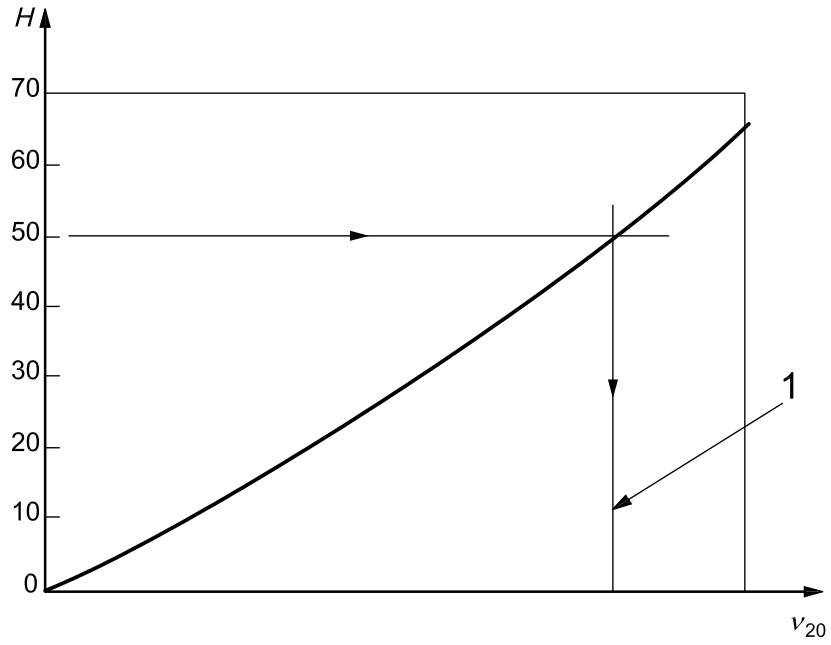

Key

v_{20} velocity, in millimetres per second

H head loss, in millimetres

1 velocity index, V_{H50}

Figure 2 — Fitted quadratic regression curve (v_{20} , H)

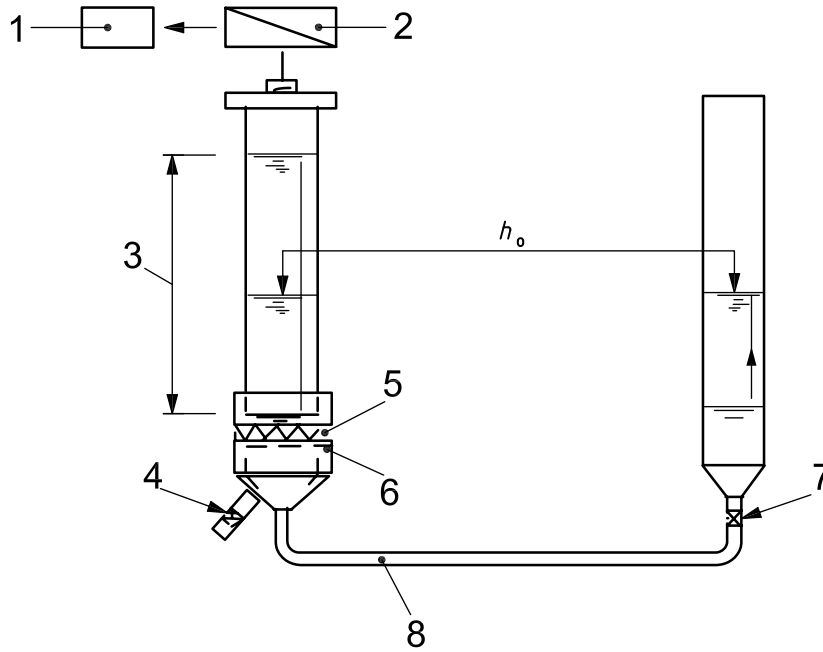

a) Weighing cell method

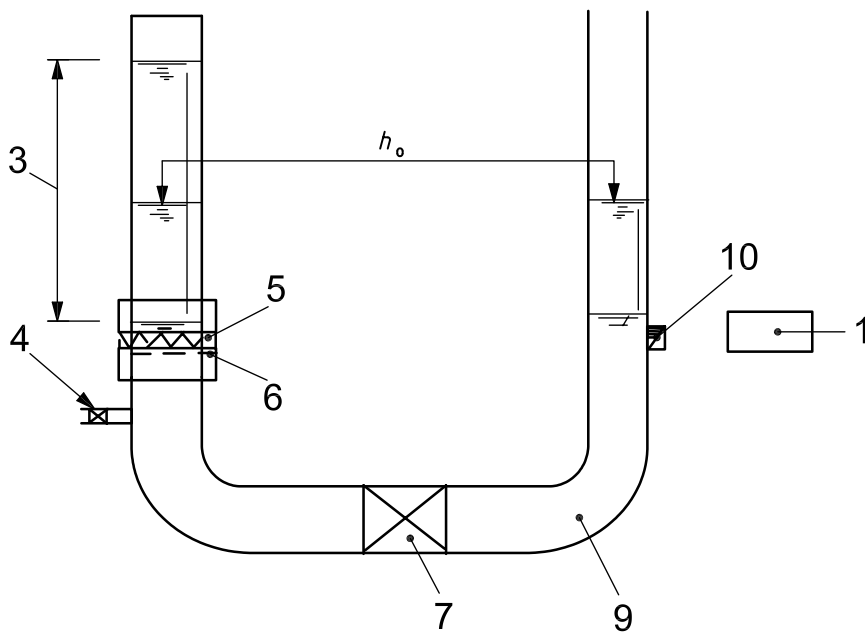

b) Pressure gauge method

Key

- | | |
|--|----------------------------|
| 1 analogue recorder or computer | 6 support grid |
| 2 weighing cell | 7 main valve |
| 3 water level difference at test start | 8 flexible connecting tube |
| 4 release valve | 9 fixed connecting tube |
| 5 specimen | 10 pressure gauge |

Figure 3 — Examples of apparatus for the falling head method

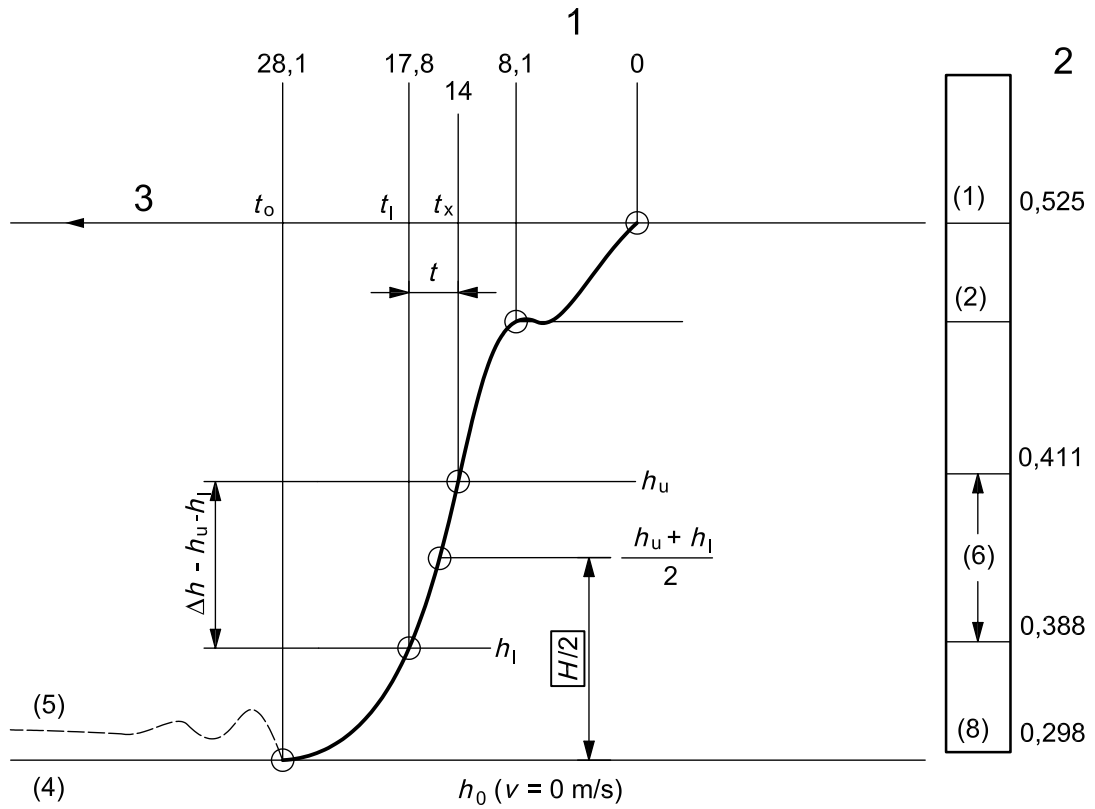

Key

- 1 time to completely open the valve
- 2 water level height, in metres
- 3 time, t , in seconds

Explanations	Remarks
(1) water level at test start	(1) – (2) range inappropriate for calculation (2) – (8) range appropriate for calculation
(2) water level after complete opening of the valve	
(8) lowest water level (reference level for calculation)	
(4) course of water level alteration (low permeable geotextile)	See Note in 6.3.7
(5) course of water level alteration (high permeable geotextile)	
(6) example for calculation	See Table D.2

Figure 4 — Example of a falling water level as recorded by an analogue writer

Annex A (informative)

Determination of the correction factor, R_T , to a water temperature of 20 °C

$$R_T = \frac{\eta_T}{\eta_{20}} = \frac{1,762}{1 + 0,033\ 7T + 0,000\ 22T^2} \quad (\text{dimensionless})$$

with

$$\eta_T = \frac{1,78}{1 + 0,033\ 7T + 0,000\ 22T^2} \quad (\text{mPa}\cdot\text{s})$$

where

η_T is the dynamic viscosity at T °C, in millipascal seconds;

T is the water temperature, in degrees Celsius;

η_{20} is the dynamic viscosity at 20 °C, in millipascal seconds;

R_T is the correction factor to a water temperature of 20 °C.

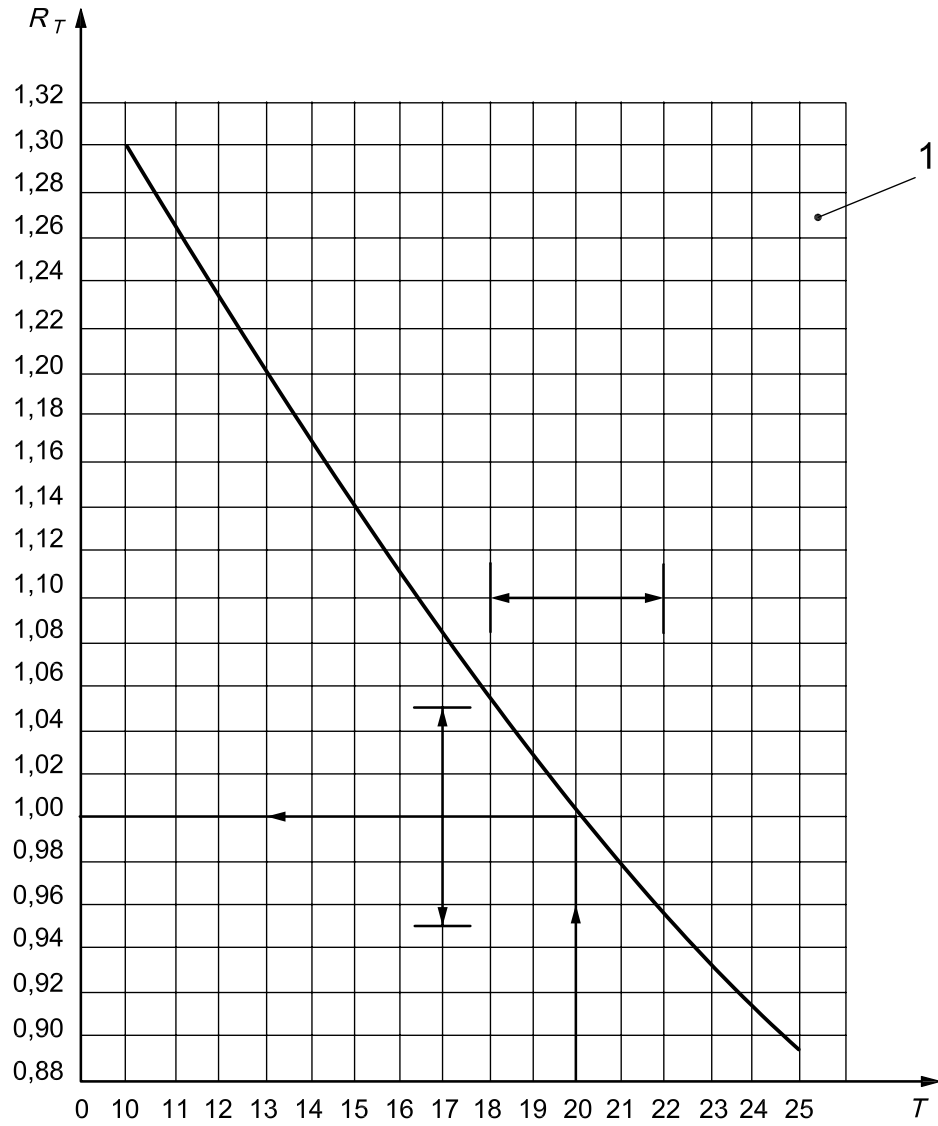

Key

- 1 temperature range from 18 °C to 22 °C (see Note in 5.2.2)
- T test temperature, in degrees Celsius
- R_T correction factor

Figure A.1 — Graphical presentation of the correction factor, R_T

Annex B (informative)

Relationship between head loss and flow velocity

The general relationship between head loss, H , and flow velocity, v , can be expressed by the quadratic function:

$$H = av + bv^2$$

Using the experimental data v and H of this annex, the best-fit quadratic curve passing through the origin can be determined through the paired terms v and H , as illustrated in Figure B.1.

This graph allows the determination of the velocity at a head loss of 50 mm.

Table B.1 — Experimental data of velocity, v , and head loss, H , after temperature correction

v_{20} mm/s	H mm
19,7	20,0
28,3	30,1
35,3	40,0
41,9	50,0
46,8	60,0

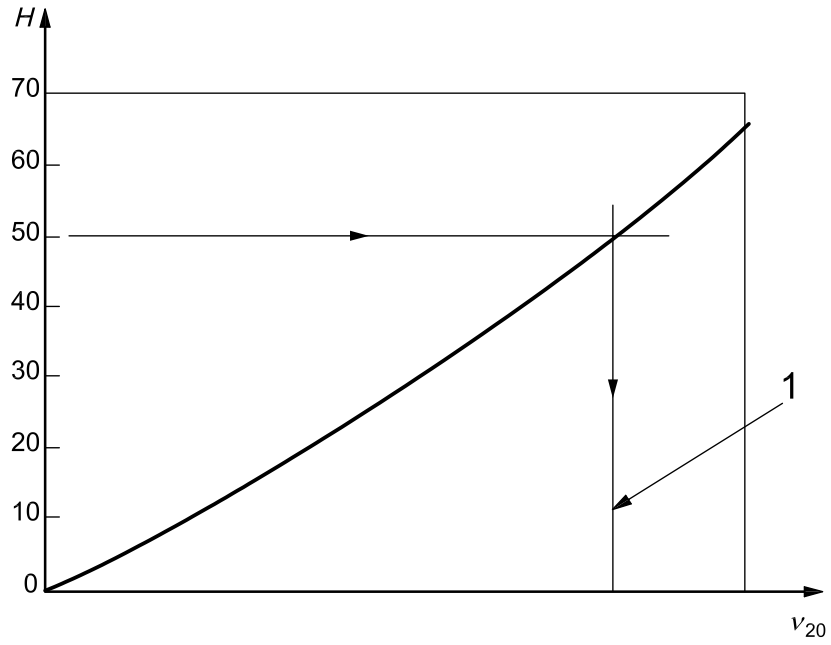

Key

- v_{20} velocity, in millimetres per second
- H head loss, in millimetres
- 1 velocity index, V_{H50}

Figure B.1 — Fitted quadratic regression curve v_{20}, H

Annex C
(informative)

Velocity index

Product designation: _____

Date: _____

Sample designation: _____

Table C.1 — Velocity index

Specimen	Velocity index (V_{H50}) at a head loss of 50 mm m/s
1	
2	
3	
4	
5	
Mean	
Maximum	
Minimum	

Annex D (informative)

Experimental data and calculations

Table D.1 — Experimental data and calculations for a geotextile or geotextile-related product specimen (constant head method)

Specimen: _____ Date: _____

Exposed area of the tested specimen: _____ m²

Product designation: _____

Laboratory temperature: _____ °C

Sample designation: _____

Head loss <i>H</i> m	Water volume <i>V</i> m ³	Time <i>t</i> s	Water temperature <i>T</i> °C	Correction factor <i>R_T</i>	Velocity <i>v</i> ₂₀ m/s	Gauge <i>v_T</i> m/s

Table D.2 — Experimental data and calculations for a geotextile or geotextile-related product specimen (falling head method)

Specimen: _____ Date: _____

Exposed area of the tested specimen: _____ m²

Product designation: _____

Laboratory temperature: _____ °C

Sample designation: _____

Chosen water level interval					Water level at <i>v</i> = 0 <i>h</i> ₀ m	Tem- perature <i>T</i> °C	Correc- tion factor <i>R_T</i> –	$\Delta h =$ (2) – (4) m	<i>t</i> = (5) – (3) s	<i>v</i> ₂₀ = (9)(8)/ (10) m/s	<i>H</i> = (2) + (4) – 2(6) m
No.	Upper limit <i>h</i> _u m	<i>t</i> _u s	Lower limit <i>h</i> _l m	<i>t</i> _l s							
(1)	(2)	(3)	(4)	(5)	(6)	(7)	(8)	(9)	(10)	(11)	(12)
1											
2 ^a	0,411	14,0	0,388	17,8	0,298	18,0	1,051	0,073	3,8	0,020	0,153
3											
4											
5											

^a For an example, see Figure 4.

